



The Frostbuster

Frost Protection by Phase Transition Better Fruit Set - Better Fruit Quality

Why Agrofrost ?

- Agrofrost is the biggest producer of frost protection machines in the world and our turnover increases year after year.
- During the last 50 years, Agrofrost has been the only company that introduced new effective solutions to fight frost.
- Agrofrost is the only company that continues to invest money in research for better solutions and better results.
- Agrofrost offers the biggest range of frost protection machines in the world, so we can always offer you the ideal solution: several models of the Frostbuster, FrostGuards Revolution & Basic, Frost Alarms, Wind Machines, Burners for Wind Machines.



The Frostbuster F501

How does it work? → Phase Transition !

Don't look for a cheaper protection per hectare because you will find none. Even more, the Frostbuster has several advantages compared to other frost protection systems: you can protect your crops in places where no water is available, or protect fruit which cannot be protected with water. It can be used not only during radiation frost but also during wind frost, and a lot of farmers use the Frostbuster **to improve their crop's fruit set**.

The Frostbuster is a trailed machine. The powerful fan is driven by the PTO of the tractor. A gas burner heats the air up to 80-85 ° Celsius. The heated air is blown between the trees through 2 outlets (1 at the left and 1 at the right). The total surface that can be protected depends on the shape and the dimensions of the plot and is maximum 8 to 10 hectares.

Instead of warming up the atmosphere, the Frostbuster uses phase transition to protect your orchards and vineyards. In a few words: by controlling the ice forming and by recuperating the energy that is liberated when vapor changes into ice, it provides an excellent protection with a minimum input of energy.

Please visit our website and learn all about it: www.agrofrost.eu

Applications



The FrostGuard can be used to protect vineyards, any kind of fruit trees (apples, pears, peaches, avocados, apricots, nectarines, citrus, ...) and all kind of berries. It works also on some flowers like chrysanthemums.

The Trailed Frostbuster F501: our Top Model



During the last 15 years, the Frostbuster has proven to be very effective and very reliable. The F501 is already the third generation of the Frostbuster. The most important improvements, compared to the previous generation (F401), are:

- New pulse burner with burner controller and ionization sensor, which makes it the safest burner used in agriculture.
- The F501 can hold 8 or 10 gas bottles, so bigger autonomy up to 10 hours.
- Possibility to start up the burner automatically, depending on the RPM of the fan: if a certain speed level (RPM of fan) is exceeded, the burner will start automatically. When the speed drops back below this level, the burner will be switched off.
- Gear box with overrunning clutch.

Technical Data	
Length	4300 mm
Width	1450 mm
Height	1650 mm
Weight without gas cylinders	1680 kg
Maximum capacity	8 to 10 hectares
Average gas consumption	35 kg/hour
Min. required HP of tractor	65 HP

Safety and comfort features

- Acoustic alarm if the temperature is too high.
- New pulse burner with ionization protection system: this makes it the safest burner in the agricultural business.
- Possibility to start up the burner automatically, depending on the RPM of the fan.
- Possibility to adjust the temperature from the driver's seat.

The 3-point models: F252 - F252H - F152

In many countries, farmers do not have tractors of 65 hp or more. To help these farmers, we decided to develop a few 3-point mounted machines, that require less horsepower.

These machines have a 2-speed gear box. On the lower speed, less horsepower is needed. Of course, the protected area will be smaller. We can also install a special impeller in the fan to reduce the needed power to 25 hp.

To have most weight as close to the tractor as possible, the fan is mounted vertically and two gas bottles are put in front of the fan.

The F252 can be delivered with the outlets below or with the outlets in a higher position (F252H). There's also a version with only 1 outlet to one side.

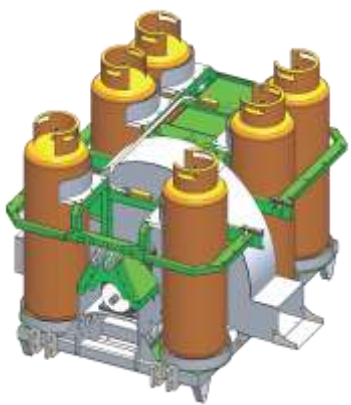
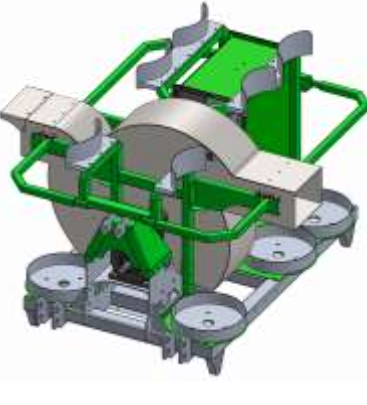
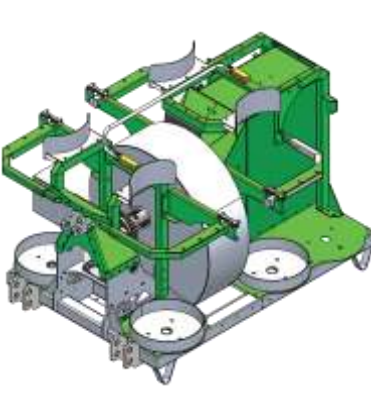

The Three Models of the 3-point mounted Frostbusters

Model	F252	F252H	F152
			
Outlet	2 low outlets	2 higher outlets	1 low outlet
Application	orchards, some vineyards, greenhouses	vineyards, crops like strawberries, blueberries	orchards, some vineyards, greenhouses
Protected area	4 - 8 hectares	4 - 8 hectares	2 - 4 hectares
Dimensions L x W x H (in mm)	1710 x 1720 x 1190	1710 x 1720 x 1240	1710 x 1500 x 1190
Weight	350 kg	350 kg	320 kg
Gas consumption	30 kg/hour	30 kg/hour	20 kg/hour
Min. required HP of tractor	55 HP	55 HP	40 HP

Advantages

- Better fruit set and better fruit quality.
- The most economic protection system on the market.
- Multifunctional: can be used for many applications.
- Not a fixed installation but mobile so it can be used in every plot.
- Low consumption therefore a low price per hour.
- Low maintenance costs.
- Environmental friendly : burning of propane gas.
- No risk on diseases or loss of fertilizers as in case of the use of water.
- Can be used to heat up plastic tunnels.
- Works not only during radiation frost but also during wind frost.
- No permits needed (like for construction or environment).

A few examples of the results of the Frostbuster

Cherries - Minimum Temperature -4,7 °C - Full flowering - 2200 trees per hectare

Results	Protected	Unprotected	Difference
Yield per tree	11,3 kg	2,7 kg	8,6 kg
Yield per hectare	24.860 kg	5.940 kg	18.920 kg
Quality	Excellent	Poor	



Protected



Unprotected

Apples and Pears

Results	Farm 1	Farm 2	Farm 3
Number of hectares	5	9	9,3
Minimum temperature	- 9 °C	- 5,2 °C	- 6,3 °C
Number of fruits per tree			
protected	126,4	127,6	91
not protected	16,8	61	44,8
Number of good fruits per tree			
protected	117,4	120,8	89,3
not protected	12,4	57,0	40,6

Contacts		Telephone	E-mail
US, Canada, Australia, New Zealand, Eastern Europe	Marc Polleunis	+48 728 562 373	m.polleunis@gmail.com
France, England, Benelux, Italy, Spain, Portugal, Austria, Switzerland, South America	Patrik Stynen	+32 495 517689 +44 1580 291565	patrik@agrofrost.be

Your dealer:



More information: www.agrofrost.eu - info@agrofrost.be - Tel.: +32 495 517689